

MPM3630: 0.85V at 3A schematic

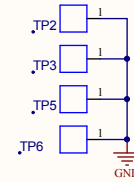

MPM3620A: 3.3V at 2A schematic

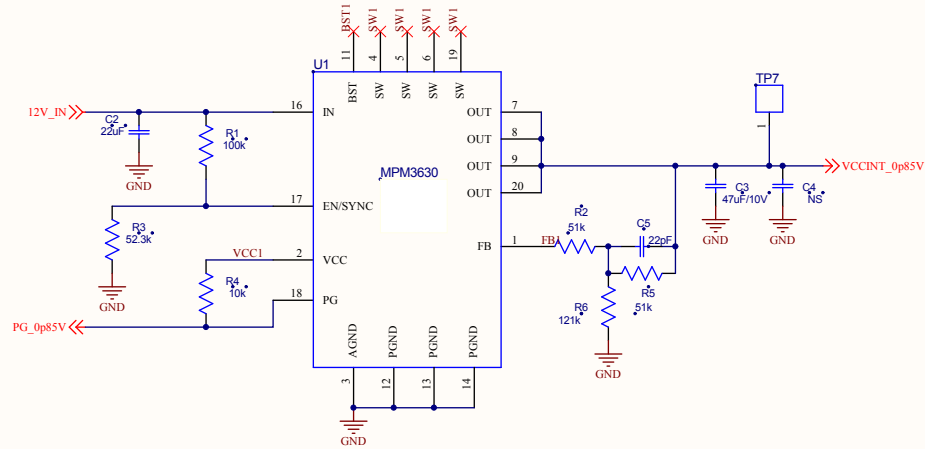
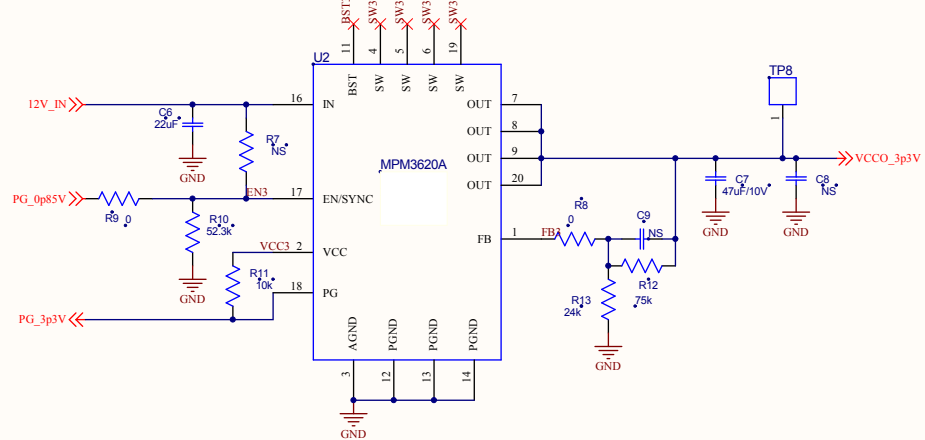

Title			
MPS power solution reference design for Xilinx ZynqUS+ Low Power			
Size	Number	1 of 2	Revision
B			00
Date:	10/3/2017	Sheet of	
File:	C:\Users\...Rail 1 and 3.SchDoc	Drawn By:	Christian Cross

MPM3630: 1.8V at 3A schematic

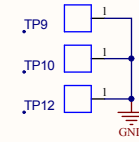
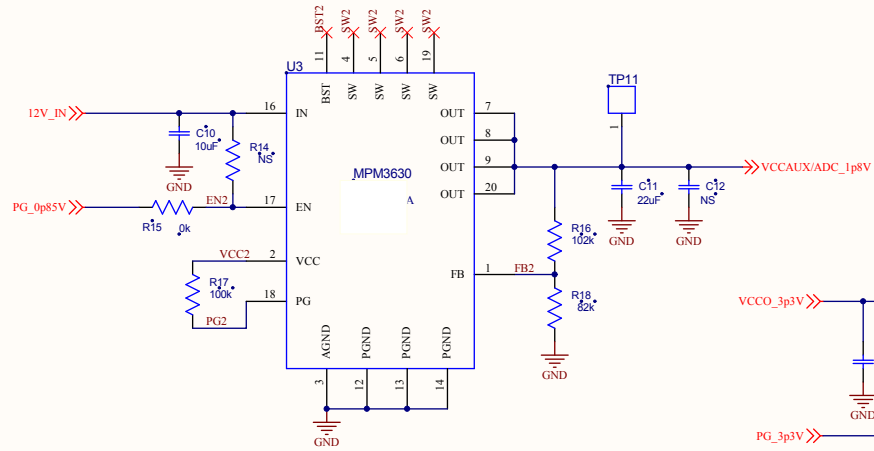

MP20043: 1.2V/2.5V at 300mA each

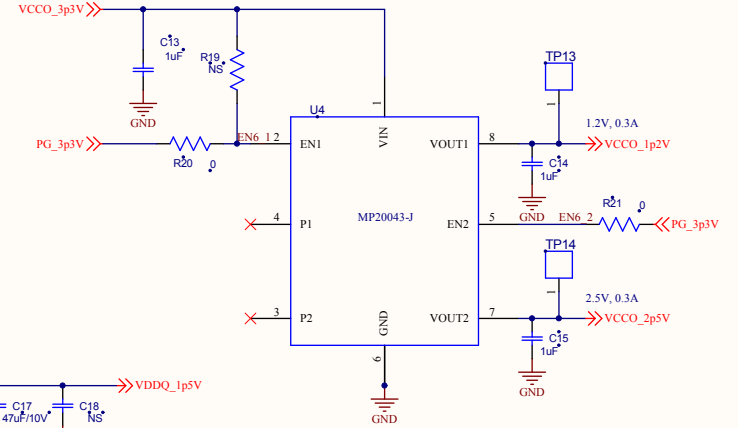

MPM3620A: 1.5V at 2A schematic

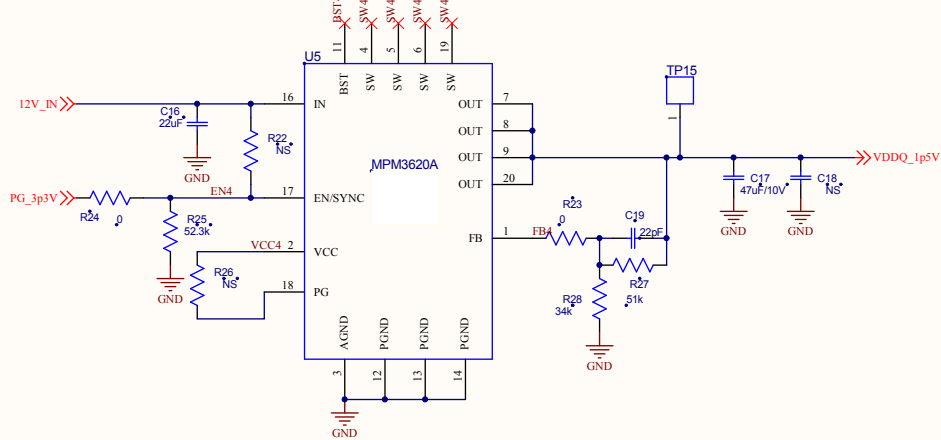

Title			
MPS power solution reference design for Xilinx ZynqUS+ Low Power			
Size	Number	Revision	
B	2 of 2	00	
Date:	10/3/2017	Sheet of	
File:	C:\Users\...Rail 2 and 4.SchDoc	Drawn By:	Christian Cross